

MIDGETBOX



G1/4"

5.5 /



II 3/3G D IIB T 135 zone2
II 2/2GD c IIB T 135 zone1

50000cps 20

PP

ATEX

/	G1/4"
	G1/8"
	3
	5.5 /
	80
	8 Bar
	0 mm
	0.5
	60

工作压力 (2~8 Bar)
耗气量 (NL/分钟)

*流量是依据水在20℃及表列扬程下所测得

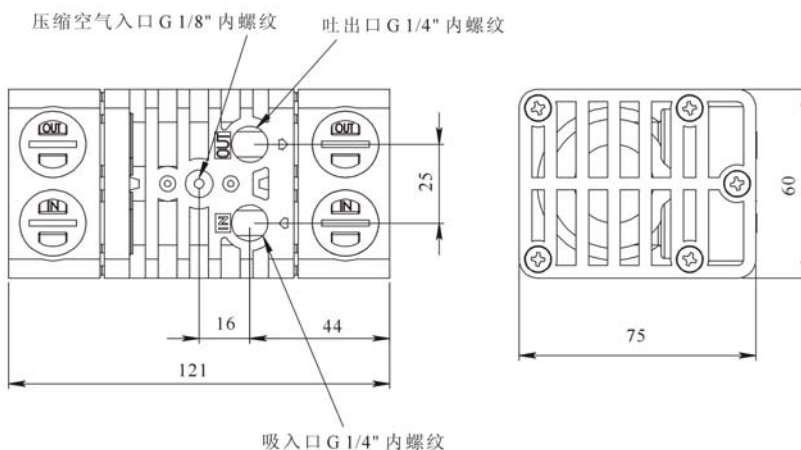
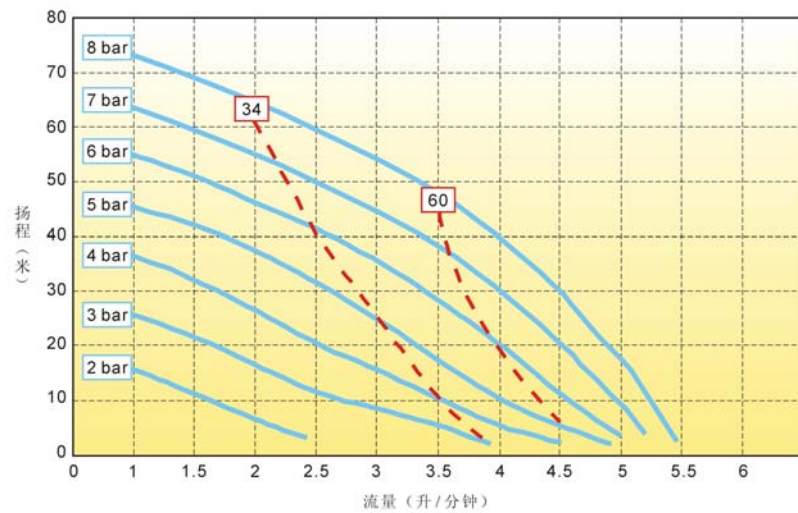

单位: mm

CUBIC 15



G3/8"

18 /



II 3/3G D IIB T 135 zone2
II 2/2GD c IIB T 135 zone1

5000cps 20

PP

ECTFE



PP ECTFE

ATEX

/	G3/8"
	G3/8"
	3
	18 /
	80
	8 Bar
	0.5 mm
	PP 1
	ECTFE 1.5
	PP 60
	ECTFE 95

■ 工作压力 (2-8 Bar) *流量是依据水在20℃及表列扬程下所测得
■ 耗气量 (NL/分钟)

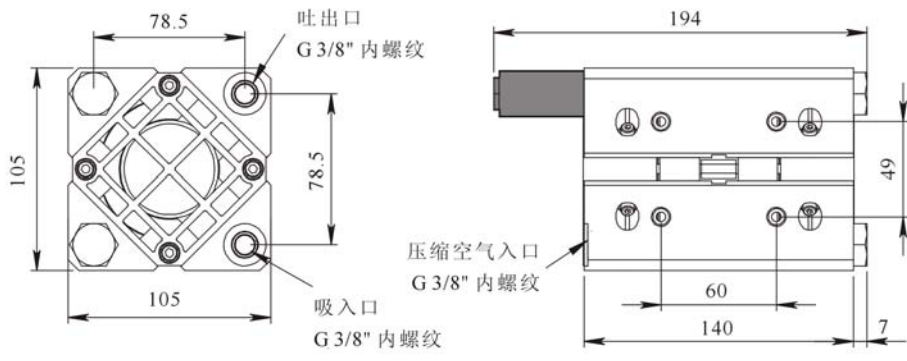
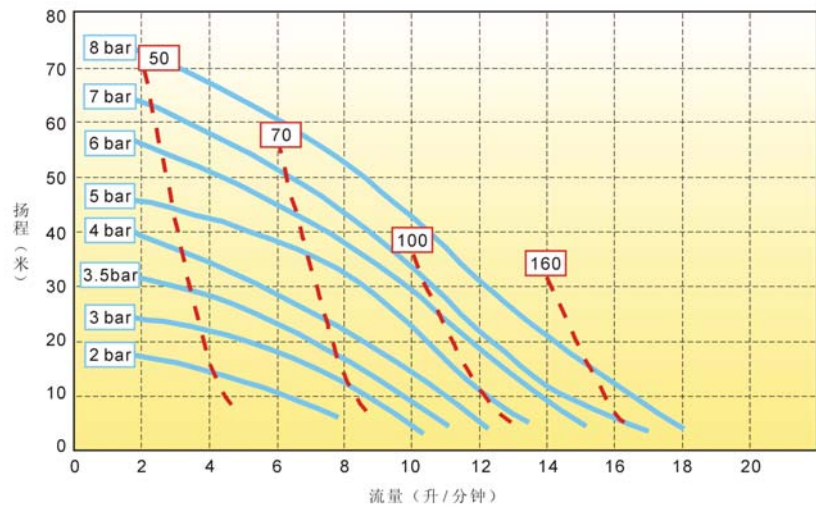

单位: mm



MICROBOXER



G1/2"

34 /



II 3/3G D IIB T 135 zone2

II 2/2GD c IIB T 135 zone1

50000cps

20

PP PVDF

316

ATEX

/	G1/2"
	G1/4"
	6
	34 /
	80
	8 Bar
	2 mm
	PP 1.6
	PVDF 1.9
	2
	316 3.8
	PP 60
	PVDF 95
	95
	316 95

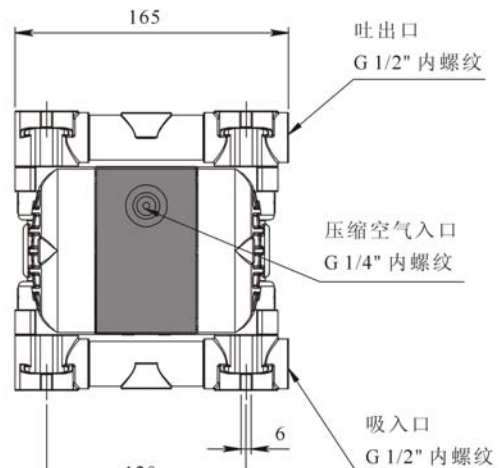
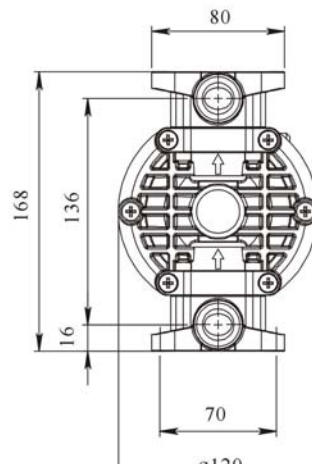
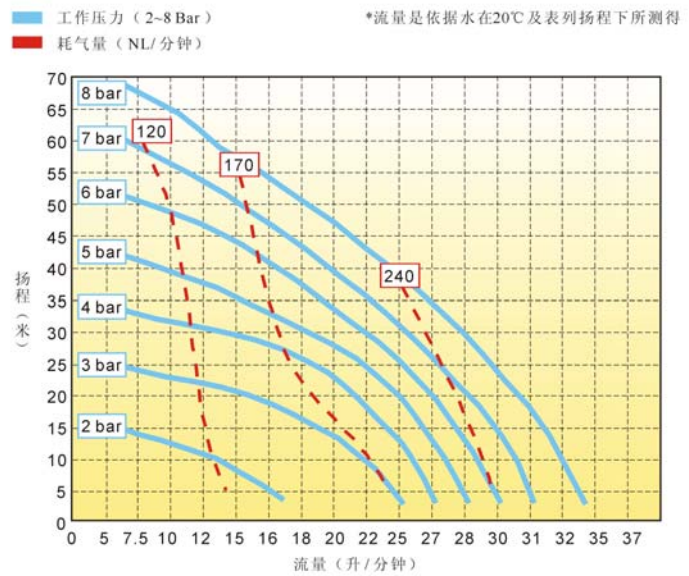



MINIBOXER - BOXER 50



G1/2"

55 /



II 3/3G D IIB T 135 zone2

II 2/2GD c IIB T 135 zone1

5000cps 20

PP PVDF 316

ATEX



BOXER 50 PP



BOXER 50 PVDF



BOXER 50



MINIBOXER 不锈钢 316

/	G1/2"	DN15
		G3/8"
		5
		55 /
		80
		8 Bar
		4 mm
	PP 3.6	PVDF 4.2
	4	316 6.5
	PP 60	PVDF 95
	95	316 95

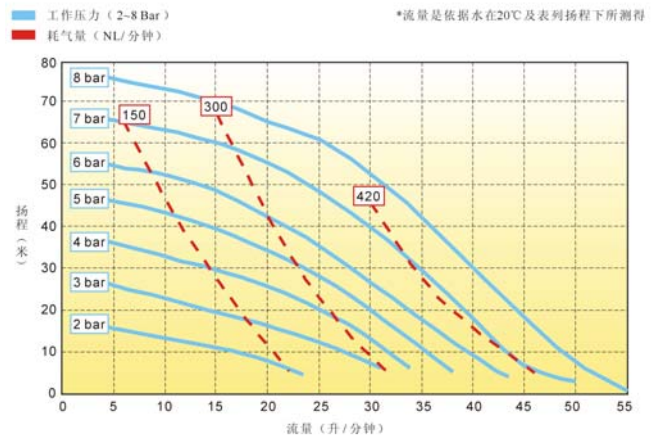

BOXER 50	mm	MINIBOXER	mm
----------	----	-----------	----

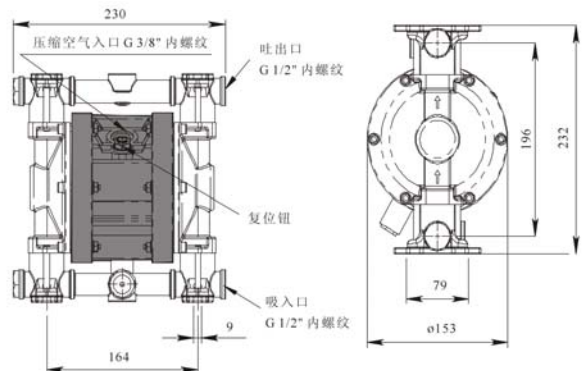
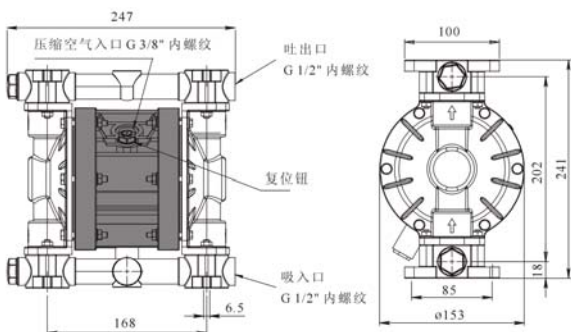



BOXER 80-81



G1"



110 /

II 3/3G D IIB T 135 zone2
II 2/2GD c IIB T 135 zone1

50000cps 20

PP PVDF 316

ATEX

/	G1"	DN25
		G3/8"
		6
		110 /
		80
		8 Bar
		4 mm
	PP 5	PVDF 6.5
	6.5	316 10.5
	PP 60	PVDF 95
	95	316 95

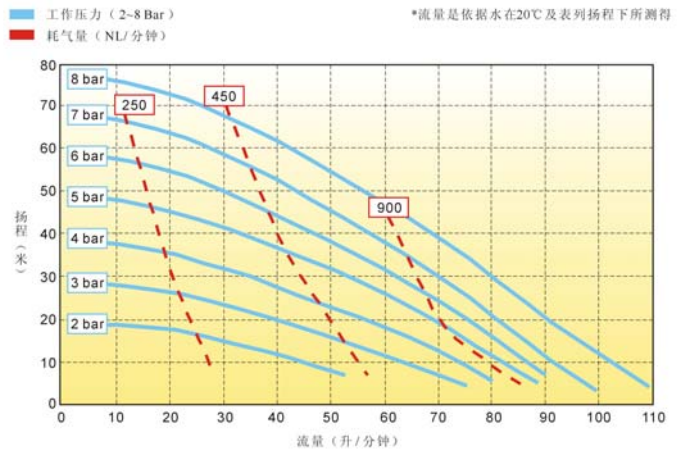

BOXER 80 mm BOXER 81 mm

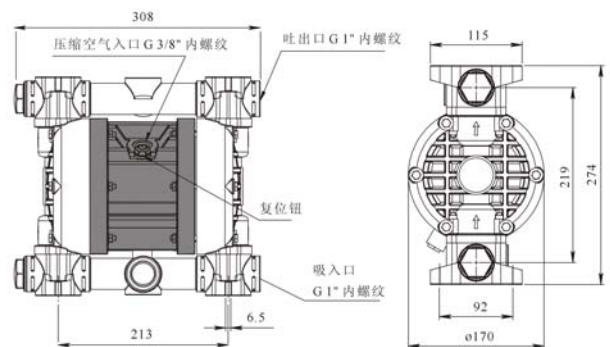
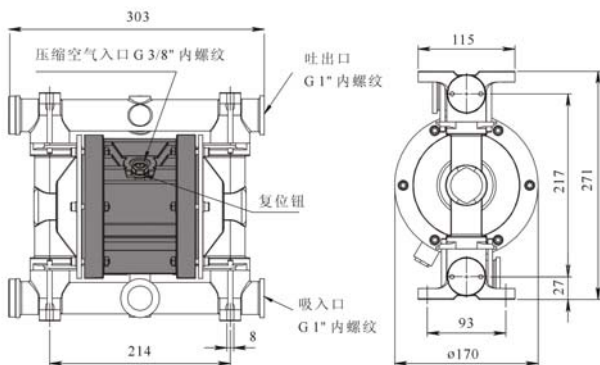



BOXER 100



G1" 170 /



II 3/3G D IIB T 135 zone2
II 2/2GD c IIB T 135 zone1

5000cps 20

PP PVDF 316

ATEX

/	G1"
	DN25
	G3/8"
	5
	170 /
	80
	8 Bar
	4 mm
PP 7.5	PVDF 8.5
	8.2
	316 11
PP 60	PVDF 95
95	316 95

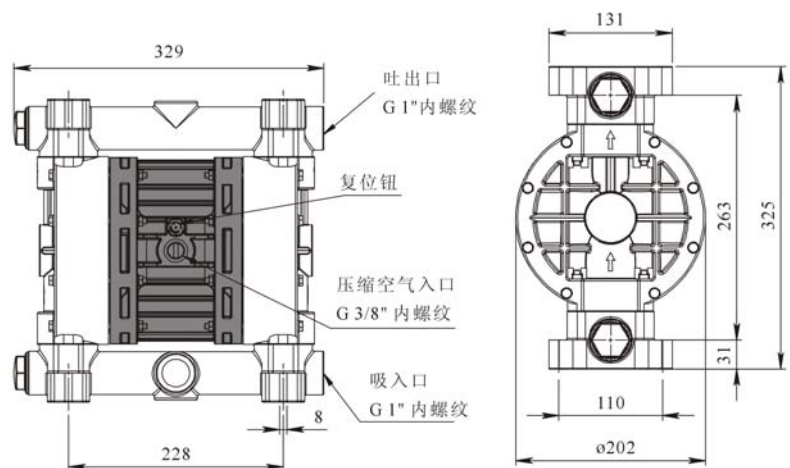
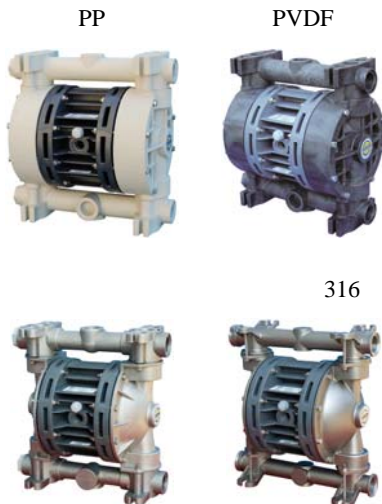
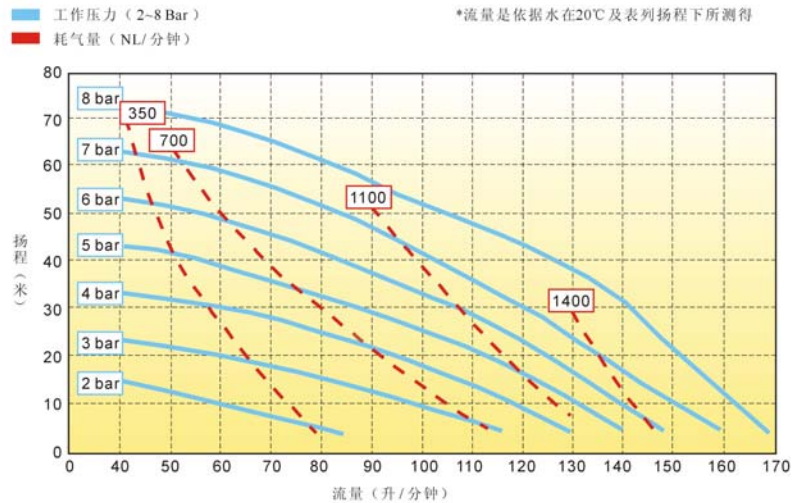

mm



BOXER 150



G1"1/4

240 /



II 3/3G D IIB T 135 zone2

II 2/2GD c IIB T 135 zone1

50000cps

20

PP PVDF

316

ATEX

/	G1"1/4	DN32
	G1/2"	5
		240 /
		80
		8 Bar
		5 mm
	PP 12	PVDF 14
		16
		316 21
	PP 60	PVDF 95
	95	316 95

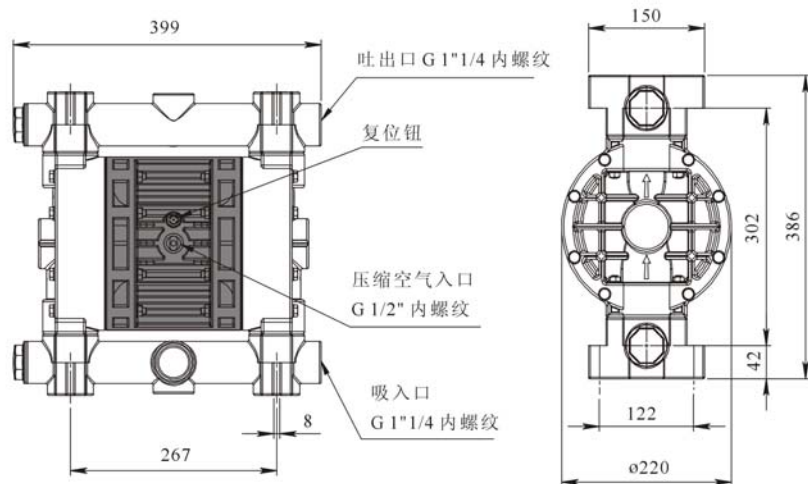
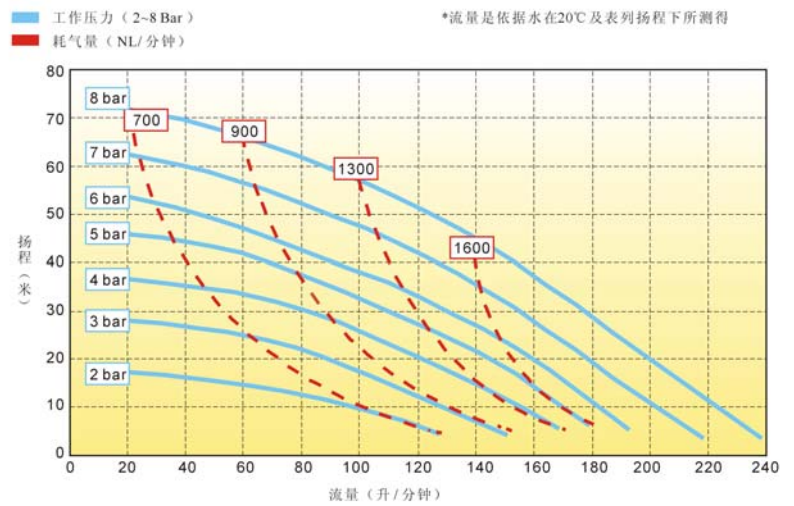

mm



BOXER 251



G1"1/2

380 /

II 3/3G D IIB T 135 zone2

II 2/2GD c IIB T 135 zone1

5000cps 20

PP PVDF

316

ATEX

/	G1"1/2	
	DN40	
	G1/2"	
	6	
	380 /	
	80	
	8 Bar	
	6 mm	
	PP 16	PVDF 20
		21
		316 32
	PP 60	PVDF 95
		95
		316 95

工作压力 (2-8 Bar)
耗气量 (NL/分钟)

*流量是依据水在20℃及表列扬程下所测得

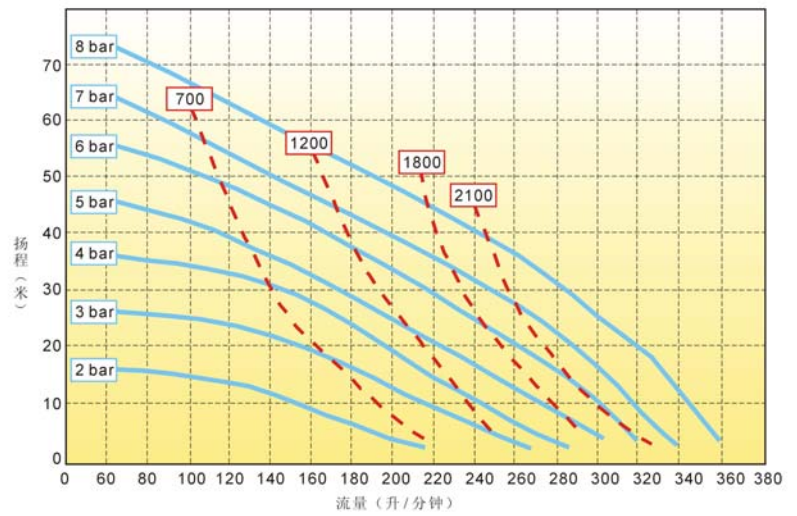

PP



PVDF



316

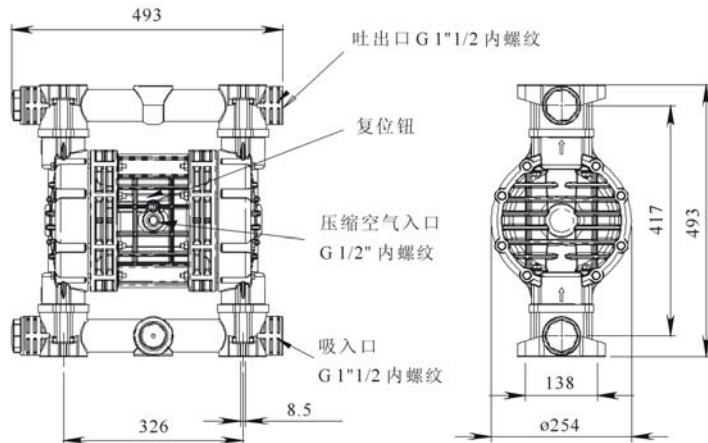

mm



BOXER 502

G2" / 680



II 3/3G D IIB T 135 zone2
II 2/2GD c IIB T 135 zone1

50000cps 20

PP PVDF

316

ATEX

/	G2"	DN50
		G1/2"
		4
		680 /
		80
		8 Bar
		8 mm
	PP 48	PVDF 65
	49	316 54
	PP 60	PVDF 95
	95	316 95

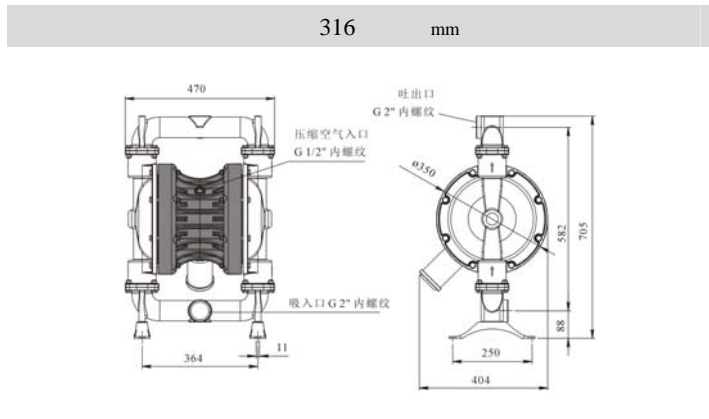
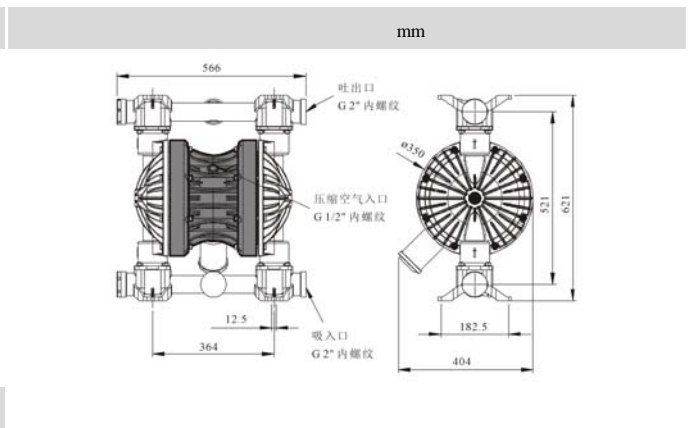
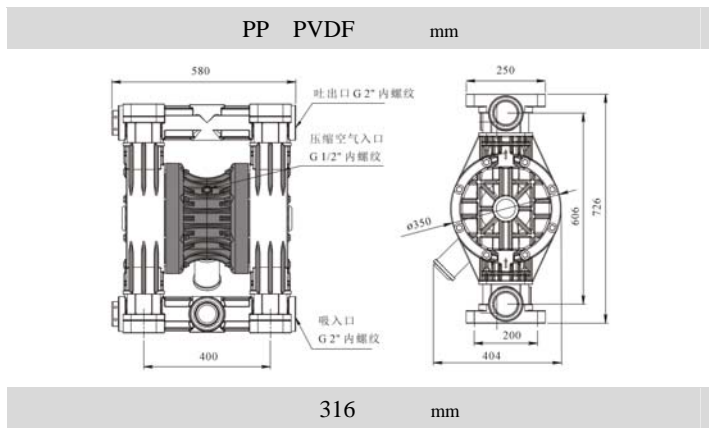
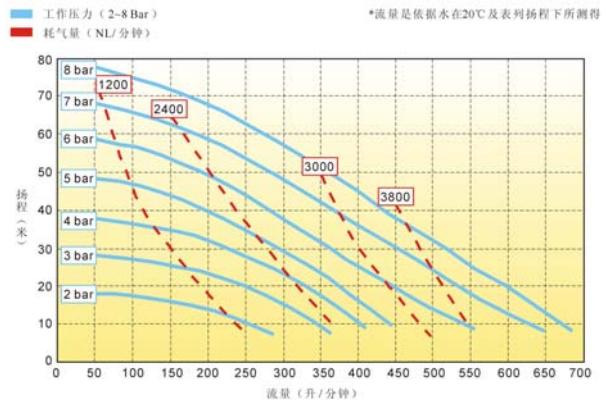



BOXER 503



G3" 960 /



II 3/3G D IIB T 135 zone2

II 2/2GD c IIB T 135 zone1

5000cps 20

PP PVDF 316

ATEX

/	G3"	DN80
	G3/4"	
	5	
	960 /	
	80	
	8 Bar	
	10 mm	
PP 50	PVDF 67	
	66	
	316 71	
PP 60	PVDF 95	
	95	
	316 95	

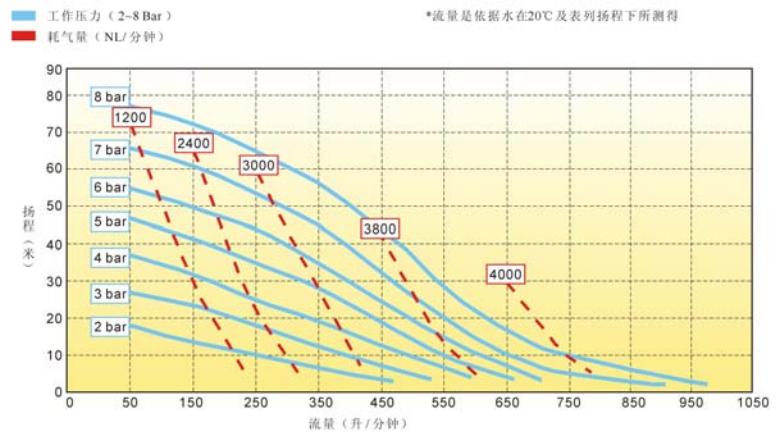

PP	PVDF	mm	316	mm
----	------	----	-----	----

